

Buying and Fixing-Up Old Tools: Adding Electronic Speed Controls

Bob Clark

What to Buy?

Always Buy Quality

Make a list of tools you would want

For example my lathe wish list:

- Oneway 24 -36 Lathe
- Robust American Beauty Lathe
- Stubby 1000
- VB-36

I ended up with a VB-36 for less than half price of new

What to Pay?

I Have a Half Price Rule

Never pay more than half price for a used tool

Some exceptions (for example)

- Oneway Lathes
- Robust Lathes
- Oneway Chucks
- Vicmarc Chucks

Why the Half Price Rule?

Sometimes Things go on Sale



POWERMATIC

20% OFF
Powermatic 3520B Lathe

~~\$3,999.99~~
\$3,199.99

Cannot be combined with any other offers or discounts. Does not qualify for Frequent Buyer points.

The advertisement features a yellow Powermatic 3520B lathe on a black background. The lathe is shown from a three-quarter view, highlighting its motor, headstock, tailstock, and bed. A wire safety cage is positioned above the lathe. The Powermatic logo is visible on the lathe's body. To the right of the lathe, the brand name "POWERMATIC" is displayed in a black oval with yellow text. Below this, a large "20% OFF" is written in orange, followed by "Powermatic 3520B Lathe" in white. The original price "\$3,999.99" is shown in white with a strikethrough, and the sale price "\$3,199.99" is shown in large white text. At the bottom, a disclaimer in white text states: "Cannot be combined with any other offers or discounts. Does not qualify for Frequent Buyer points."

What If The Seller Does Not Believe In The Half Price Rule? Extra Stuff!

☆ Jet 1642 EVS Wood Lathe - \$1650 (Hanford) 

image 1 of 5



What to Pay?

Do not Nickel and Dime the Seller

If it has fair price do not dicker price

Get the seller to add some extras

- Chucks
- Faceplates
- Turning Tools
- Maybe they can help with delivery

Craig's List Finds

☆ **ROCKWELL DELTA 20" BANDSAW 28-350 VERTICAL UPRIGHT COMMERCIAL Band Saw - \$400 (All Original Very Clean)** 

image 1 of 23

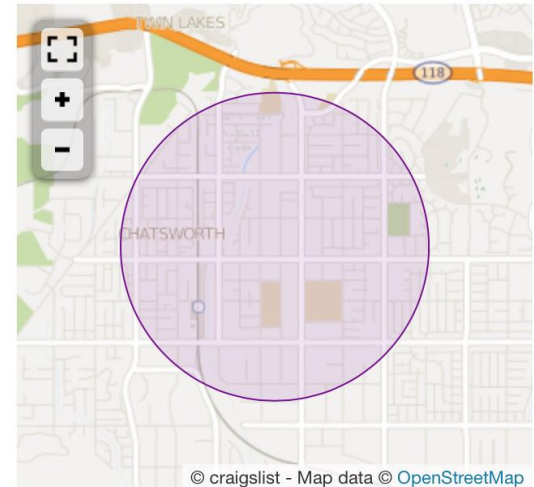

© craigslist - Map data © OpenStreetMap

[\(google map\)](#)

condition: **excellent**

make / manufacturer: **ROCKWELL DELTA**

model name / number: **28-350**



ROCKWELL DELTA 20" BANDSAW

Craig's List Finds

ROCKWELL DELTA 20" BANDSAW
MODEL 28-350 ELECTRIC VERTICAL UPRIGHT COMMERCIAL

CONDITION: Unit is in working condition. UNIT has been restored with new paint. The table needs to be hook back on and the blade guide needs to be installed. Both are present. Blade NOT included.

115V, 1 PH, 60 Hz
NEEDS ALL ADJUSTMENTS SET

DESCRIPTION: ROCKWELL DELTA MODEL 28-350 ELECTRIC VERTICAL UPRIGHT COMMERCIAL BAND SAW
MODEL: 28-350
BAND SAW BLADE LENGTH 11"- 9"

ITEM: 0716-1393

YOUR COST: \$400.00

CONTACT: [show contact info](#) OR [show contact info](#)

What is Horsepower?

- .746 Kilowatts equals one horsepower
- 3300 foot ponds of torque in one minute

What is Torque?

- Torque is a vector force measure in pound feet of force.

Motor Manufactures Lie About Horsepower



120 or 240 Volts

120 volts

- Can work up to 1 ½ horsepower

240 volts

- Needed for 2 horsepower and greater

I can help you if you do not have
240 volts in your shop

Variable Speed Control?

AC or DC

DC Advantages

- Price if you are paying retail

AC Advantages

- Constant torque
- Used 3-phase motors are not expensive
- Hybrid drive controllers make installation easy

Variable Speed Control DC Torque Curve

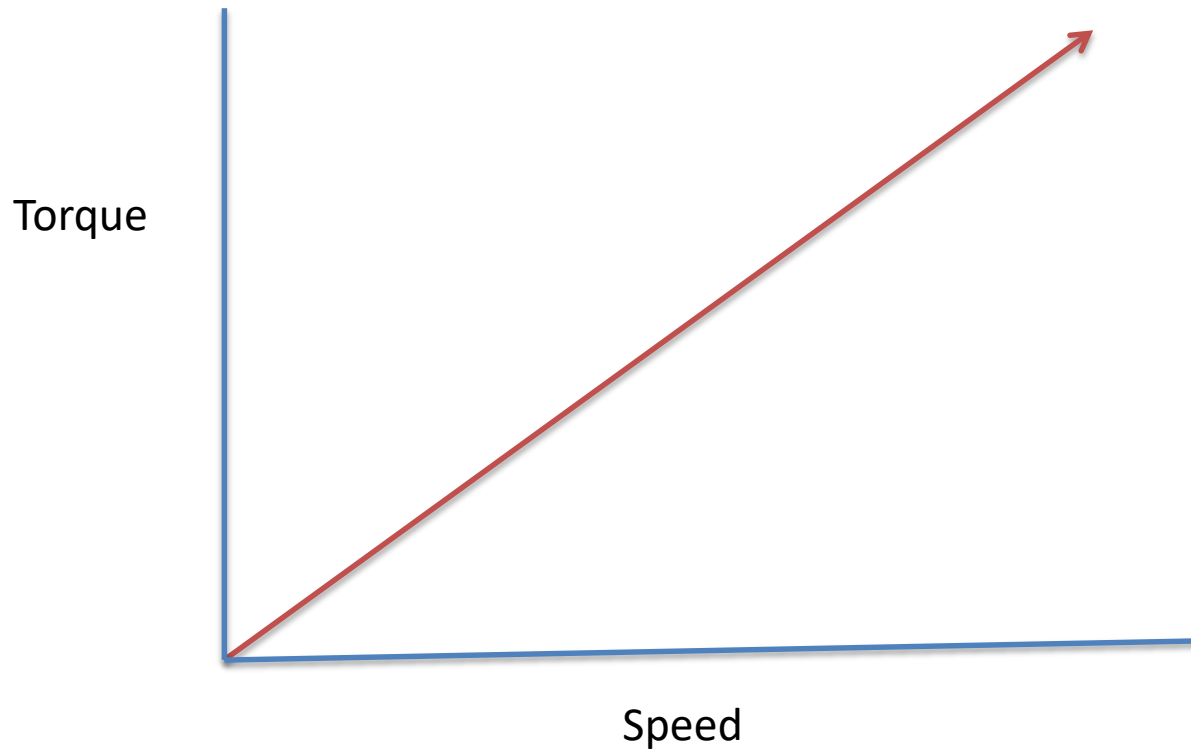

Variable Speed Control AC Torque Curve

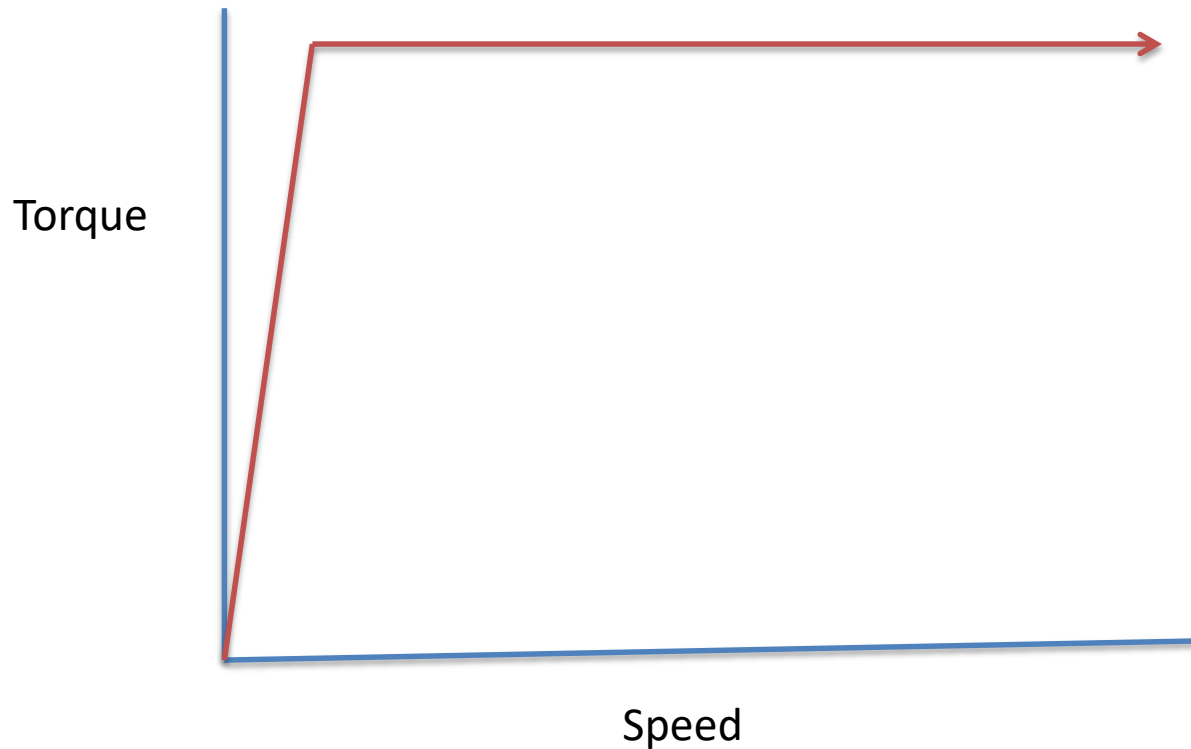

DC Speed Control

Like 0



Tweet



View Larger

Buy Now

Our Guarantee

Leeson DC Variable Speed Control 1-1/2 HP 220v

Part# 1046640001

Our price: \$1067.95

Heavy/Oversize Item: add \$20.00 shipping

[View Product Details](#)

Size:

1-1/2 HP 220v

Temporarily out of stock

Expected in stock Sep 22, 2017 - [More Info](#)

Qty.

 **ADD TO CART**

 [Add to wish list](#)

 [Add to commonly bought items list](#)

AC Variable Speed Control?

What You Need

Variable Frequency Drive (VFD)

- 120 or 240 volt single phase input with 240 volt three phase output

3-Phase Induction Motor

- 240V
- Sized to match your needs
- Inverter rated is better

AC Variable Speed Control?

What You Need

Variable Frequency Drive (VFD)



AC Variable Speed Control?

What You Need

Thermally Enclosed Fan Cooled (TEFC)
240 volt, 3-Phase Motor

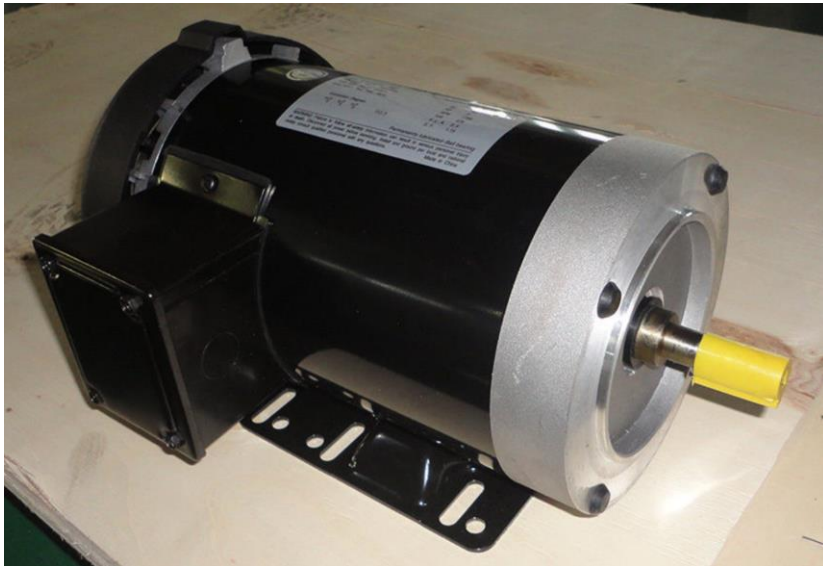

AC Variable Speed Control?

What You Need

Check The Motor ID Plate

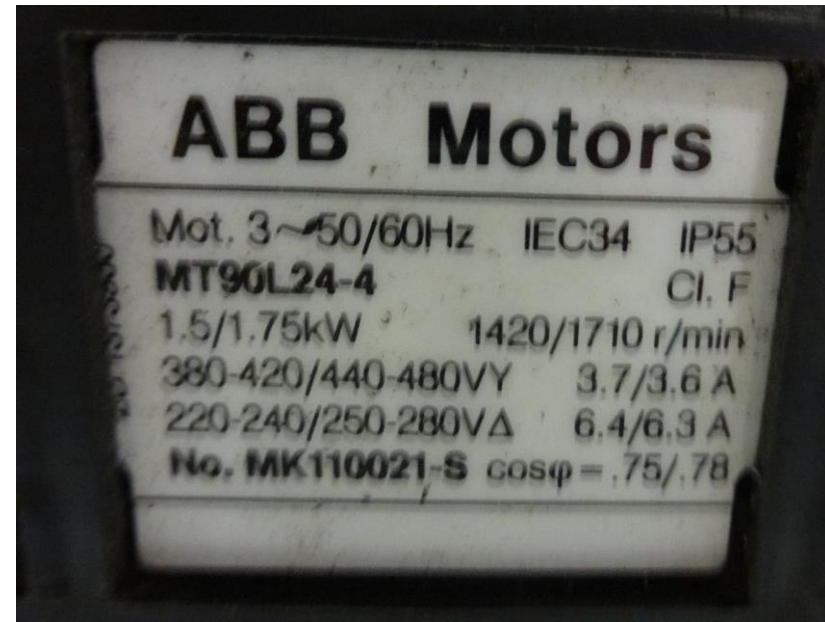
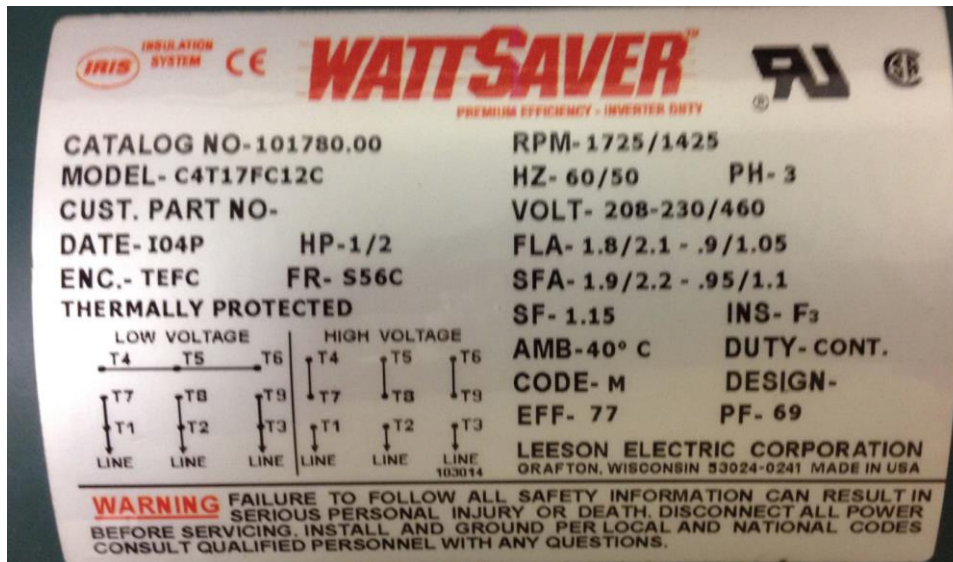

Download the motor specification sheet

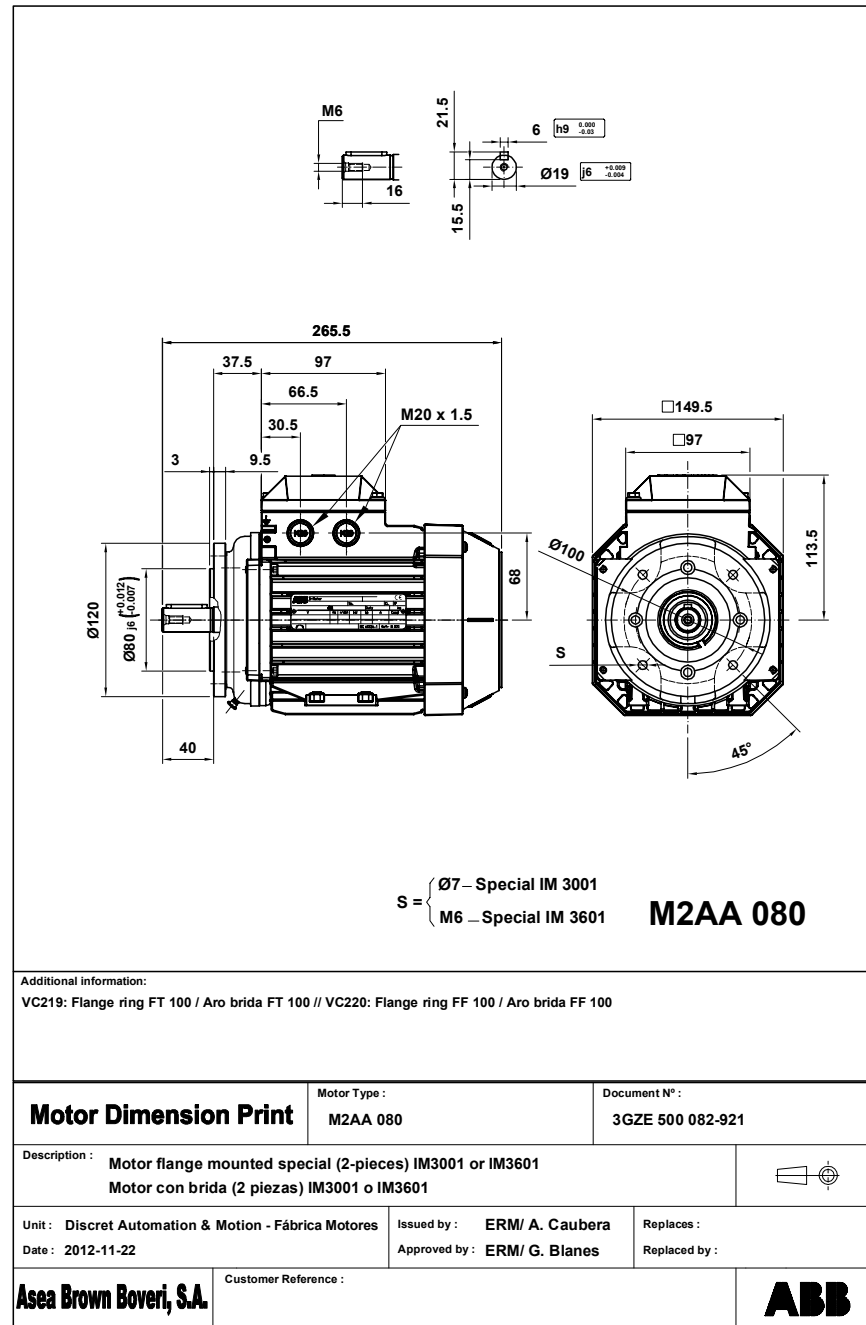



KBAC Wiring is Easy

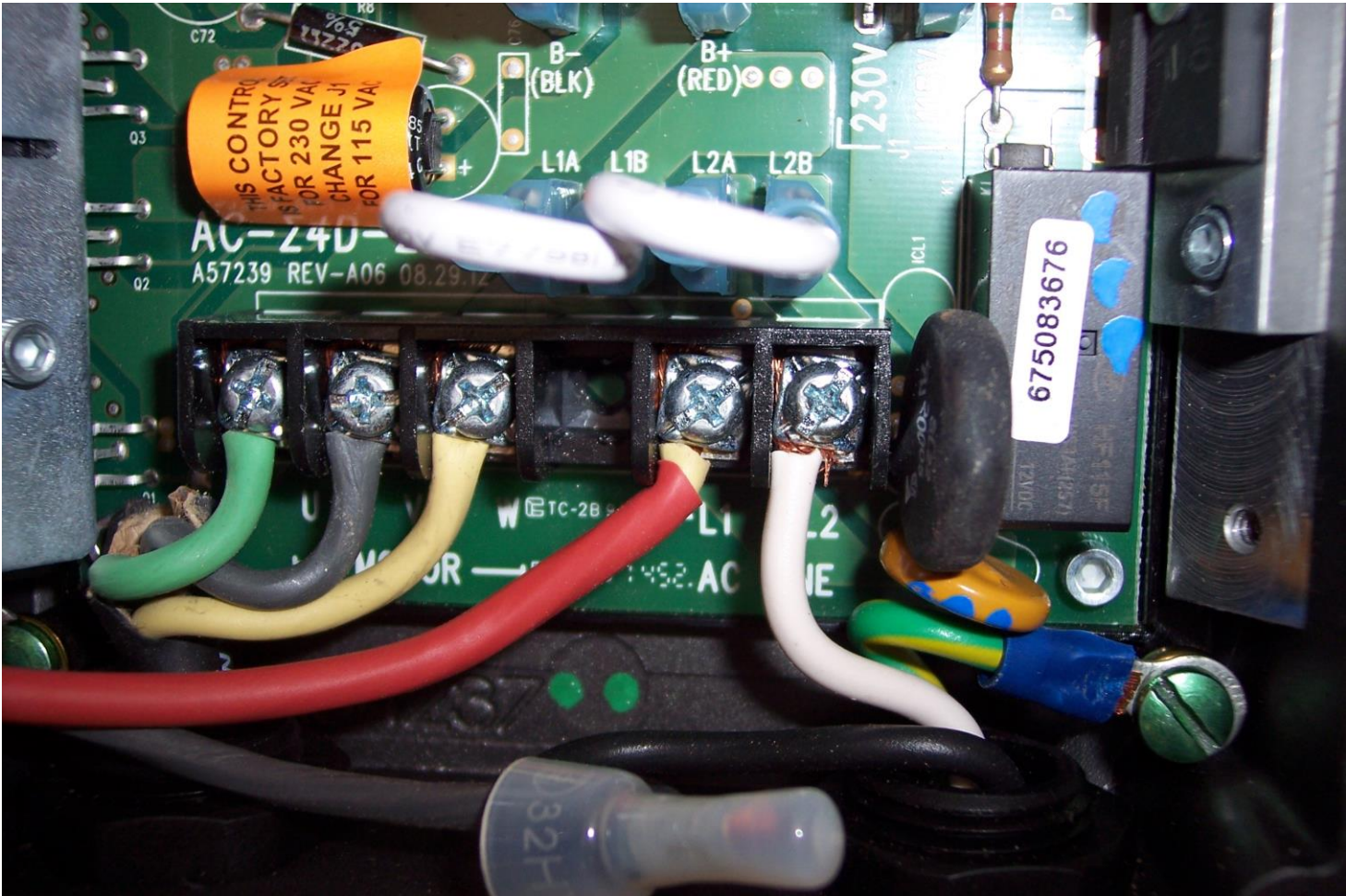

KBAC
Select
115 or
230 volt
jumper

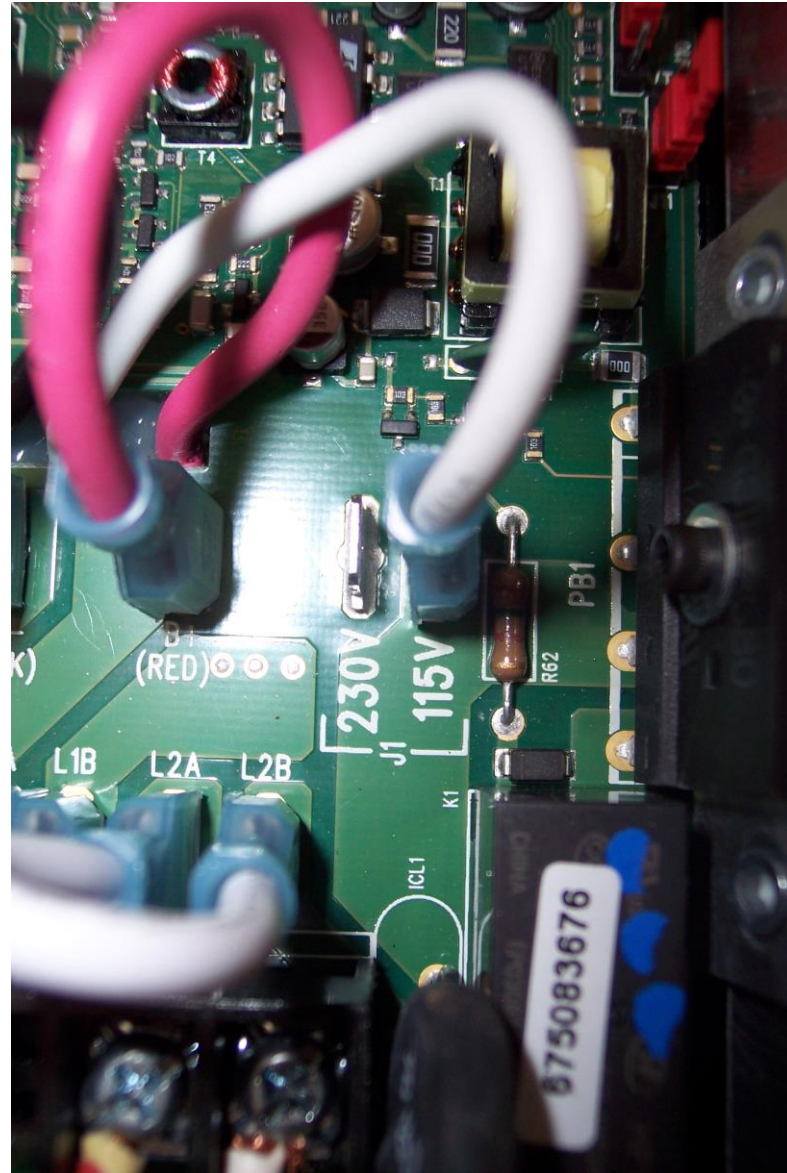

KBAC
Select
Motor HP
Hertz
100 or
200%

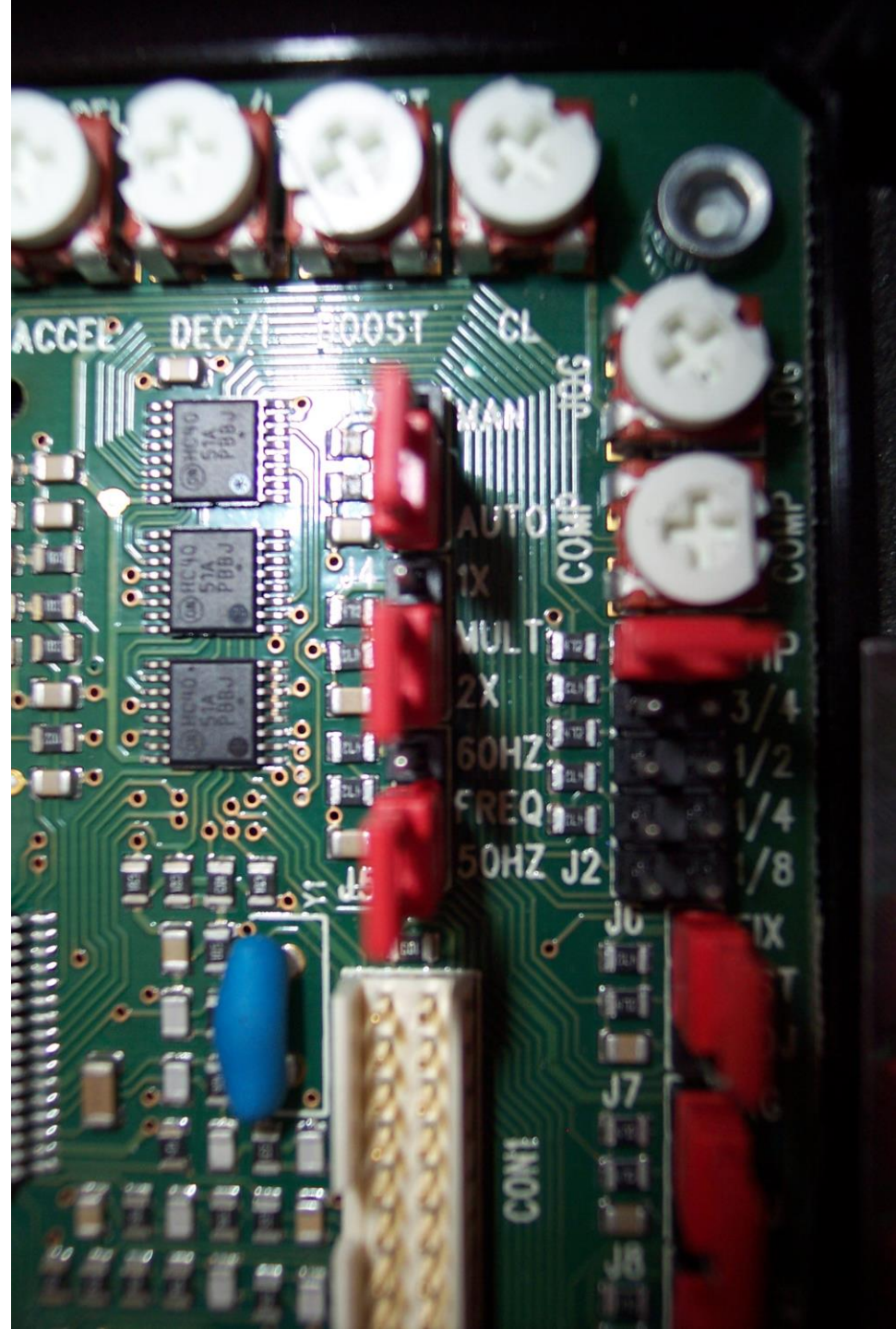

A Hybrid Drive Can be Built for You



KB-Controls.com

Your motor speed control solution provider!

Power Transmission 8803
Sorensen Ave. Santa Fe
Springs, CA, 90670
800- 266-7650
(Fax) (866) 705-1648
Sales@KB-
Controls.com

My Mini Lathe Vicmarc VL100



Down Load the Owner's Manual

VICMARC LATHE SERIES



Owner's Manual

VL100

VL175

VL200 Short & Long Bed

VL300 Short & Long Bed



Vicmarc Machinery Pty Ltd
Manufacturers of Quality
Woodturning Lathes and Accessories

Check out the Manufacturer's Parts

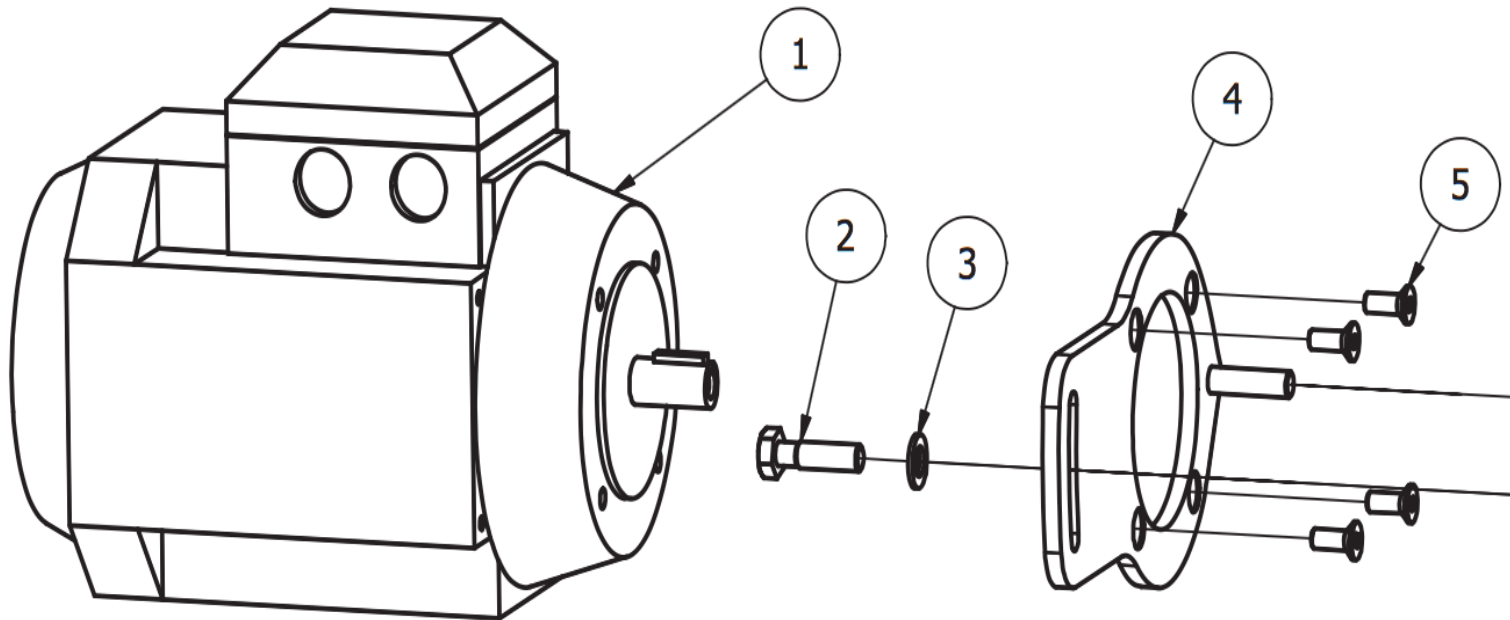



Changing the Belt Position



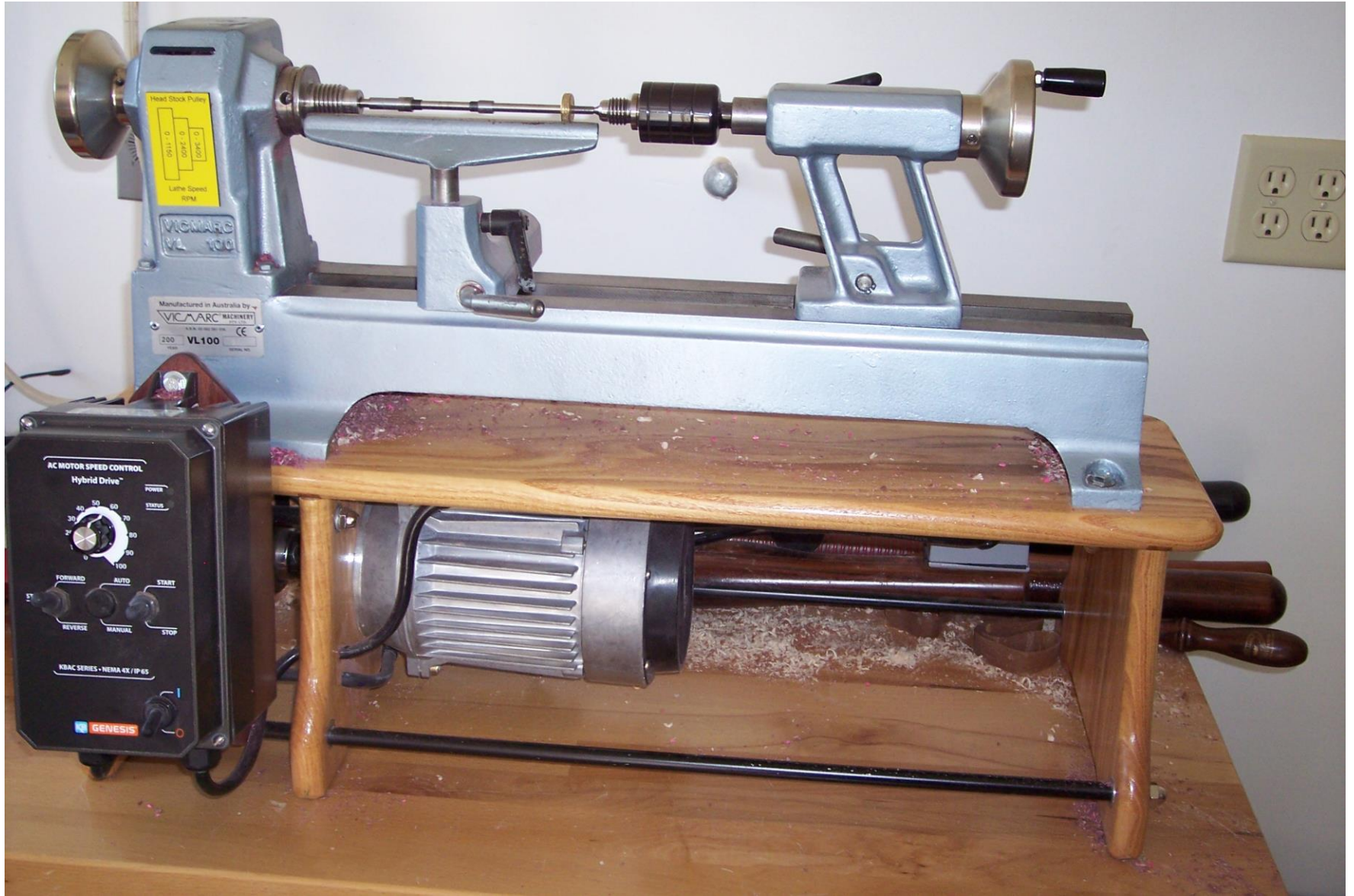

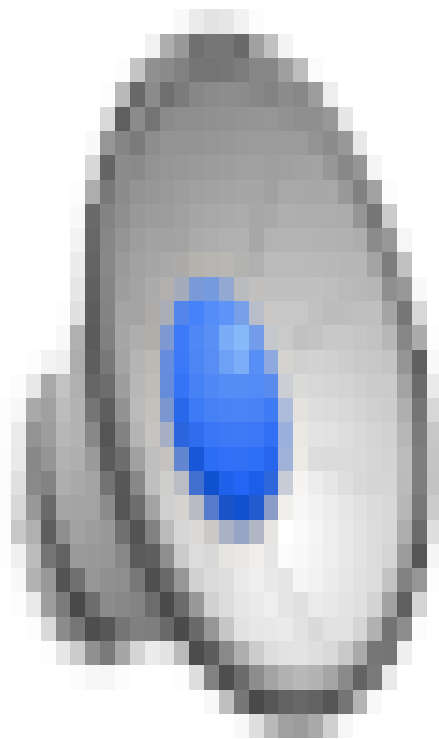

Useful Links

McMaster-Car Online Catalog

- <https://www.mcmaster.com>

McMASTER-CARR®

levers

Zinc Adjustable-Position Handle

with M8 x 1.25 mm Threaded 40mm Long Stud, 45mm Projection



Color

- Black
- Orange

Each

ADD TO ORDER

\$10.80 Each
60235K82

McMASTER-CARR®

standard flat head s

Black-Oxide Alloy Steel Hex Drive Flat Head Screw

M6 x 1 mm Thread, 12 mm Long



Packs of 100

In stock
\$10.60 per pack of 100
91294A236

ADD TO ORDER

Thread Size	M6
Thread Pitch	1 mm
Length	12 mm
Threading	Fully Threaded
Head Diameter	12 mm
Head Height	3.3 mm
Countersink Angle	90°
Drive Size	4 mm
Material	Black-Oxide Alloy Steel
Fastener Strength Grade/Class	Class 10.9
Hardness	Rockwell C32
Tensile Strength	120,000 psi

Screws for a Chuck

Useful Links

Motion Industries

<https://www.motionindustries.com/productCatalogSearch.jsp>
www.motionindustries.com/productCatalogSearch.jsp

12995 Arroyo St, San Fernando, CA 91340

Industrial Supplier of Bearings, Drive Belts
Ect



Ball Bearings



Roller Bearings

Useful Links

<http://vintagemachinery.org/home.aspx>



Home About Us Discussion Forum Machine Info Photo Index Buy & Sell Tools Support OWWM

Welcome

The VintageMachinery.org web site is devoted to information on the history, restoration and generous contributions of content by thousands of dedicated members, the Vintage Machinery web site contains:

- **Historical information** on every known manufacturer of wood-working and metal-working machinery in the [Manufacturers Index](#)
- **Downloadable publications** of historical catalogs, manuals and other documents in Publication
- **Photos** of vintage machines owned and restored by our members in the Photo Index
- **Technical Information** on the restoration and use of vintage machinery in the [Vintage Machinery Classified Ads](#)
- **NEW!** **Buy and Sell** vintage machinery using the FREE [Vintage Machinery Classified Ads](#)

News:

- 08/07/2017 - [Sears hardware code 789 identified: Warren-Knight](#)
- 06/07/2017 - [Serial Number Registry added - Baldor & Powermatic](#)
- 11/22/2016 - [Powr-Kraft code TSX identified as Thor/Speedway](#)
- 10/10/2016 - [Sears/Double A grinder & bench saw manuals needed.](#)
This includes the 8" dry and 10" belt driven grinders and 8" non-tilt bench saw. If you have a Upload or contact Brian Kachadurian.

RSS Feeds:

Keep track of the latest content submission to the **VintageMachinery.org** Web Site through our RSS Feeds! content submitted to the **VintageMachinery.org** Web site.

- 📡 [Recent Classified Ad Submissions](#)
- 📡 [Recent VintageMachinery.org News](#)
- 📡 [Recent Photo Index Submissions](#)
- 📡 [Recent Manufacturers Index Submissions](#)
- 📡 [Recent Publication Reprint Submissions](#)
- 📡 [Recent Manufacturers Index Image Submissions](#)

- [Google Site Search](#) - Search the VintageMachinery.org site using the power of the Google Search Engine

©WWM Store